

INSTALLATION AND MAINTENANCE INSTRUCTIONS SCU Series Split System Air Conditioner

WARNING

The equipment covered in this manual is to be installed by trained and experienced service and installation technicians. Improper installation, modification, service or use can cause electrical shock, fire, explosion or other conditions which may cause personal injury, death or property damage. Use appropriate safety gear including safety glasses and gloves when installing this equipment.

WARNING

Risk of electrical shock. Disconnect all remote power supplies before installing or servicing any portion of the system. Failure to disconnect power supplies can result in property damage, personal injury or death.

WARNING

Installation and servicing of air conditioning equipment can be hazardous due to internal refrigerant pressure and live electrical components. Only trained and qualified service personnel should install or service this equipment. Installation and service performed by unqualified persons can result in property damage, personal injury or death.

WARNING

Before performing maintenance operations on system, turn off all main power switches to indoor and outdoor units. Turn off accessory heater power switch if applicable. Electrical shock could cause personal injury or death.

TABLE OF CONTENTS

INSTALLATION	2
START-UP	5
MAINTENANCE	5
WIRING DIAGRAMS	6
WARRANTY	8

Manufactured By
A.A.C.

A *Lennox International Company*

421 Monroe Street
Bellevue, OH 44811



INSTALLATION

General

Read this entire instruction manual, as well as the instructions supplied in separate equipment, before starting the installation. Observe and follow all warnings, cautions, instructional labels and tags. Failure to comply with these instructions could result in an unsafe condition and/or premature component failure.

These instructions are intended as a general guide only for use by qualified personnel and do not supersede any national or local codes in any way. The installation must comply with all provincial, state and local codes as well as the National Electrical Code (U.S.) or Canadian Electrical Code (Canada). Compliance should be determined prior to installation.

This unit has been **factory charged with a quantity of refrigerant (R22) sufficient for a matched indoor coil and 20 feet of refrigerant tubing.** If installed with other indoor sections or with tubing sets other than 20 feet in length, adjustments to the total system charge must be made.

This outdoor unit has been ARI rated with several Armstrong matching indoor sections for various types of installations. To obtain optimum performance, a matched indoor section must be installed. ARI ratings are based on properly charged systems running at rated indoor cfm levels. Ductwork should be specified to insure the correct indoor airflow is obtainable.

Inspection of Shipment

Upon receipt of equipment, carefully inspect it for possible shipping damage. If damage is found, it should be noted on the carrier's freight bill. Take special care to examine the unit inside the carton if the carton is damaged. Any concealed damage discovered should be reported to the last carrier immediately, preferably in writing, and should include a request for inspection by the carrier's agent.

If any damages are discovered and reported to the carrier **DO NOT INSTALL THE UNIT, as claim may be denied.**

Check the unit rating plate to confirm specifications are as ordered.

Limitations

This unit is designed and approved for outdoor use only.

The outdoor unit must not be installed with any ductwork in the airstream. The outdoor fan is not designed to operate against any additional static pressure.

The unit has been designed to operate within the range of indoor and outdoor temperatures as outlined in Table 1. Following these recommendations will minimize component failures and maximize system performance.

Outdoor	65° F* (minimum) to 115° F (maximum)
Indoor	62° F db/57° F wb to 90° F db/72° F wb

* If extended run times are anticipated below outdoor temperatures of 65° F, a low ambient kit must be installed.

Table 1

Location of Unit

Install the unit on a solid, level mounting pad. To minimize transmission of vibration, the pad should not be in direct contact with any building walls or foundations.

This unit has been designed to be located outdoors with sufficient clearance for free entrance to the inlet and discharge air openings. Adequate service clearance must also be provided. Refer to Figure 1 for a detailed description of minimum clearances. Position the unit to avoid direct contact of water, snow or ice from a roof line overhead.

Avoid placing the unit near quiet areas such as sleeping quarters or study rooms. Normal operating sound levels may be objectionable if the unit is placed near certain rooms.

Electrical Wiring

All field wiring must be done in accordance with the National Electrical Code recommendations, Canadian Electrical Code and CSA Standards, or local codes, where applicable. Refer to the unit rating plate for information needed for wire sizing and branch circuit protection. An adequately sized branch circuit disconnect should be installed, per the NEC, within sight of and readily accessible to the unit. Route properly sized copper conductors from the disconnect to the unit high voltage connections at the contactor. A properly sized ground wire must be connected to the ground screw or wire located in the control panel. Two low voltage thermostat wires must be connected to the yellow wires connected to the contactor coil. **Use copper conductors only.**

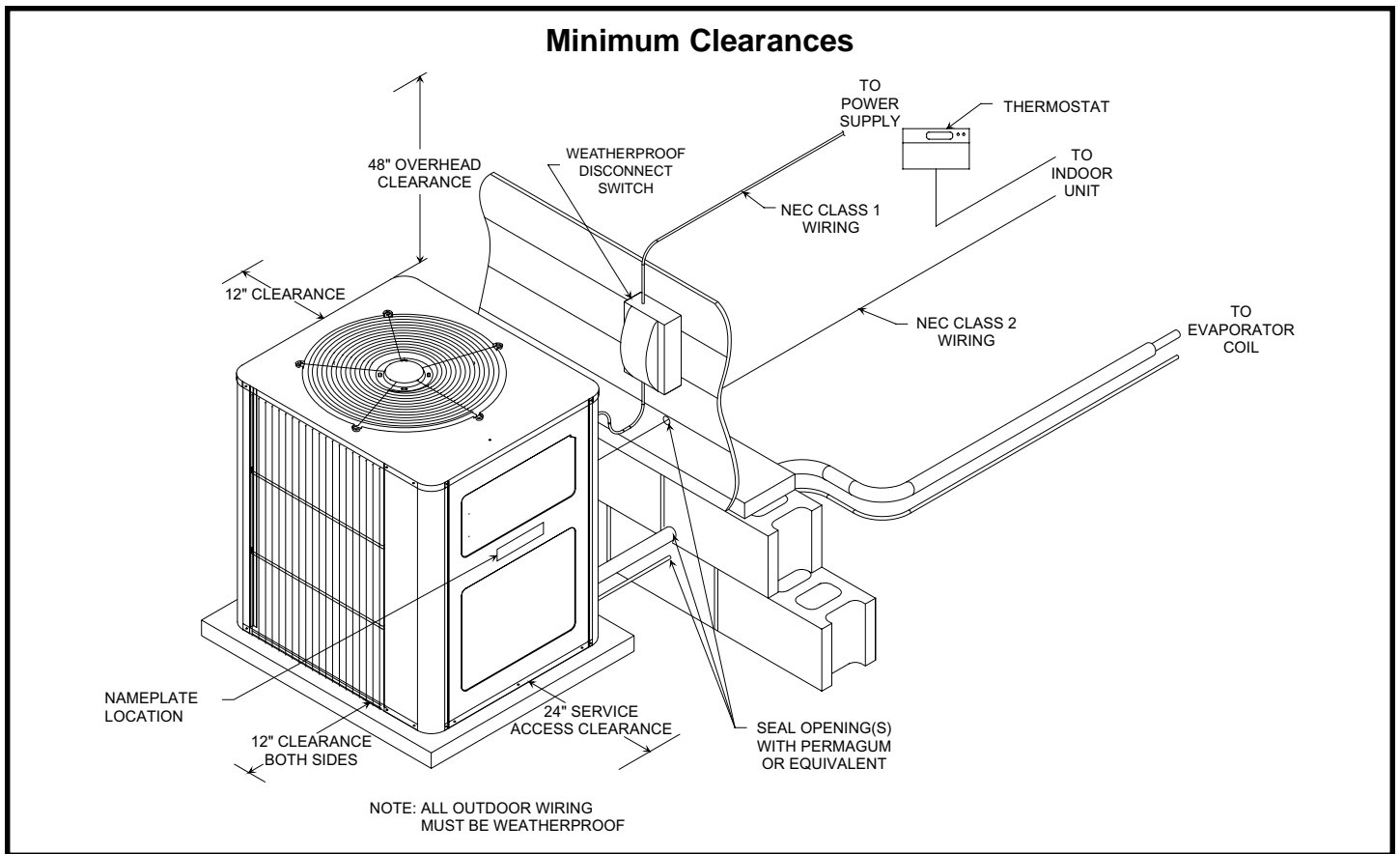

Figure 1

Refrigerant Piping Connections

Check the indoor piston orifice to see if it matches the required piston for the indoor and outdoor combination being installed. Refer to the refrigerant charge label located on the inside of the outdoor unit access panel for the correct piston orifice size requirements. Replace the piston orifice with the correct size if this size is not already installed in the indoor coil.

For optimum system performance, indoor coils should be washed with a suitable detergent to remove any residue from the coil manufacturing processes.

Refer to the following instructions when making the refrigerant piping connections:

1. The unit has been factory charged with refrigerant (R22) suitable for a matched indoor coil and 20 feet of properly sized refrigerant tubing. Refer to the unit rating plate for the exact amount of this factory charge.
2. Refer to the refrigerant charge label located on the inside surface of the outdoor unit access panel. Locate the outdoor and indoor models being installed and note any refrigerant adjustments that must be made to the system. Adjustments to the system charge must also be made if an interconnecting line set other than 20 feet is installed.

3. Route tubing to fittings on the outdoor unit vapor and liquid service valves using properly sized refrigerant grade tubing. Run the refrigerant tubing in as direct a path as possible avoiding unnecessary turns and bends.
4. Ensure that the vapor line is insulated properly and that both vapor and liquid lines are not in direct contact with floors, walls, ductwork, floor joists or other piping.
5. After wrapping the service valves with a wet rag, braze the tubing to the valve connections.
6. After brazing the tubing connections at the indoor coil, leak test the refrigerant tubing and indoor coil.
7. Following the leak test, evacuate the indoor coil and line set to a minimum of 500 microns to remove contamination and moisture.
8. After evacuation, open both the vapor and liquid service valves fully.

Factory charge contains refrigerant for condenser, evaporator and 20 feet of 3/8" line set. For line set other than 20 feet, adjust charge at 0.60 oz. per foot of 3/8" o.d. liquid line and 1.2 oz. per foot of 1/2". To obtain optimum performance, system charge should be weighed in accordance to amount specified on unit rating plate and any adjustments for additional line length over 20 feet, as stated above.

System performance may be verified by using the refrigerant charging labels provided with each unit.

In air conditioning systems, horizontal suction lines should be slightly sloped toward the condensing unit. Piping must avoid dips or low spots can collect oil. To aid in the return of oil, a trap should be installed at the bottom of any suction riser. The top end of the riser must be pitched

toward the compressor. For long vertical risers, additional traps are recommended for each additional 20 feet of pipe to insure proper oil movement.

A crankcase heater is recommended for applications where additional field added charge results in a system with a reciprocating compressor requiring more than 6 lbs. of refrigerant or a scroll compressor requiring more than 10 lbs. of refrigerant.

Suction Line Sizes					
BTU/HR	LINE SET LENGTH AND SIZE				
	12 FT.	25 FT.	50 FT.	75 FT.	100 FT.
12,000	3/4	3/4	3/4	3/4	3/4
18,000	3/4	3/4	3/4	3/4	3/4
24,000	3/4	3/4	3/4	3/4	7/8
30,000	3/4	3/4	3/4	7/8	7/8
36,000	7/8	7/8	7/8	7/8	1 1/8
42,000	7/8	7/8	7/8	1 1/8	1 1/8
48,000	7/8	7/8	7/8	1 1/8	1 1/8
60,000	7/8	7/8	7/8	1 1/8	1 1/8

Table 2

Liquid Line Sizes					
BTU/HR	LINE SET LENGTH AND SIZE				
	12 FT.	25 FT.	50 FT.	75 FT.	100 FT.
12,000	3/8	3/8	3/8	3/8	3/8
18,000	3/8	3/8	3/8	3/8	3/8
24,000	3/8	3/8	3/8	3/8	3/8
30,000	3/8	3/8	3/8	3/8	1/2
36,000	3/8	3/8	3/8	3/8	1/2
42,000	3/8	3/8	3/8	1/2	1/2
48,000	3/8	3/8	3/8	1/2	1/2
60,000	3/8	3/8	3/8	1/2	1/2

Table 3

For installations exceeding 100 feet, contact the Armstrong Air Conditioning Inc. Technical Services Department at (419) 483-4840.

START-UP

The procedure for start-up of the unit is as follows:

1. Operate the unit for a period of at least 15 minutes to allow for pressures and temperatures to stabilize. Unless matched with an indoor section using an expansion valve, the superheat method can be used to check the system refrigerant charge. It should be noted that this method is not accurate at low load conditions or at outdoor ambients above 106° F.
2. Using accurate gauges and temperature measuring devices, determine the suction line pressure and temperature as well as the outdoor ambient temperature.
3. Refer to the refrigerant charging instruction label located on the inside of the outdoor unit access panel. Locate the intersection of the measured outdoor temperature and suction line pressure on the chart.
4. If the suction line temperature is higher than the intersection temperature, the system is undercharged. If the actual suction line temperature is lower than the chart temperature, the system is overcharged.

Discharge Thermostat (if used)

Some models come equipped with a discharge thermostat (loss of charge control) to guard against the compressor overheating from loss of charge. The temperature cut out for this control is set at 250°F, as determined by compressor manufacturer's recommendation. **Discharge temperatures exceeding 250°F will cause compressor oil breakdown that will lead to premature compressor failure.** If the control trips during unit operation, a problem exists within the system. Check for the following as possible causes:

- Low system charge
- High discharge pressures

A thorough inspection of the system should be made to determine the cause. The discharge gas temperature may be verified by attaching an electronic type thermometer or thermocouple to the discharge line near the control.

The control resets automatically. If the unit does not have a discharge thermostat, an add-on kit is available.

MAINTENANCE

WARNING

Before performing maintenance operations on system, turn off all main power switches to indoor and outdoor units. Turn off accessory heater power switch if applicable. Electrical shock could cause personal injury or death.

Homeowner Maintenance

Leaves and other large obstructions should be carefully removed from the outdoor coil surfaces without damaging the fin surface of the coil.

Routinely clean or change the indoor air filter. Should the coil become dirty, thus restricting airflow, call a qualified service person to carefully clean the coil surface.

Dealer Maintenance

An annual inspection by a qualified service person should be performed to ensure continued quality performance.

Outdoor coil surfaces should be cleaned, taking care not to damage the fin surface of the coil.

Several weep holes located in the unit base should be inspected and cleaned, if necessary, to ensure that proper drainage can occur.

All electrical wiring and connections should be inspected; as should all physical connections of individual components within the units.

CONNECTION DIAGRAM

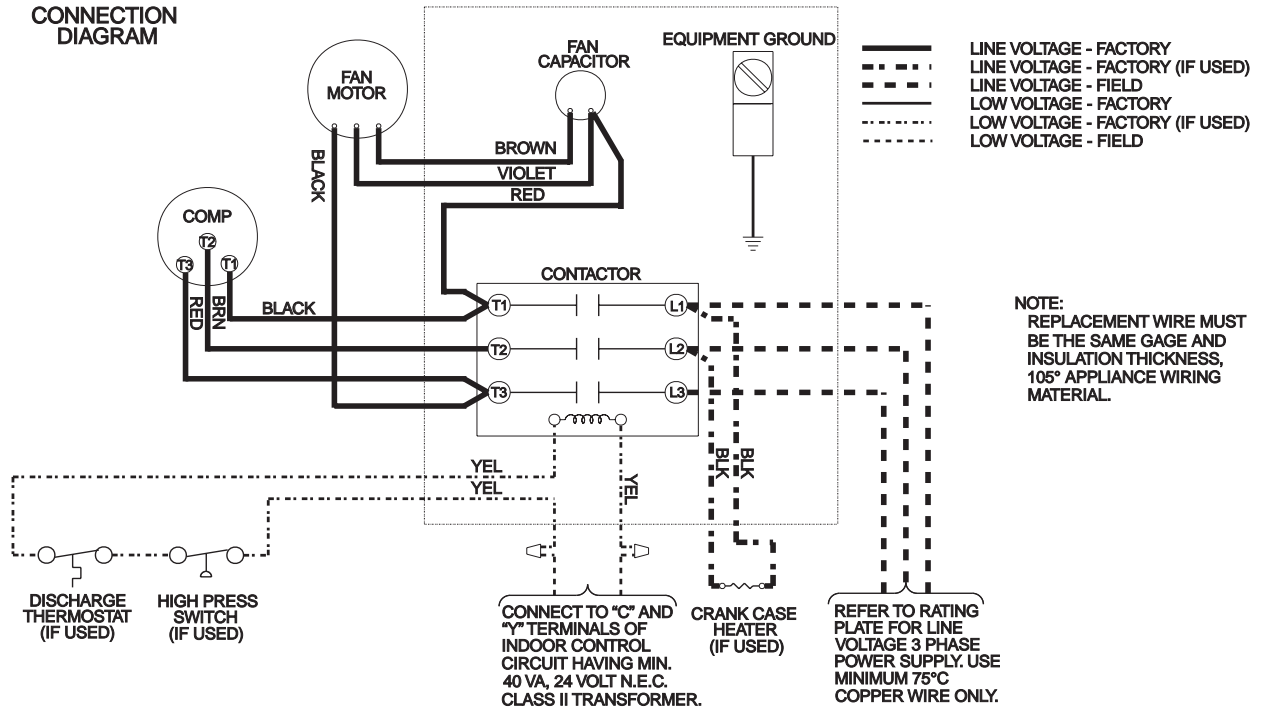

SCHEMATIC OF POWER CIRCUIT

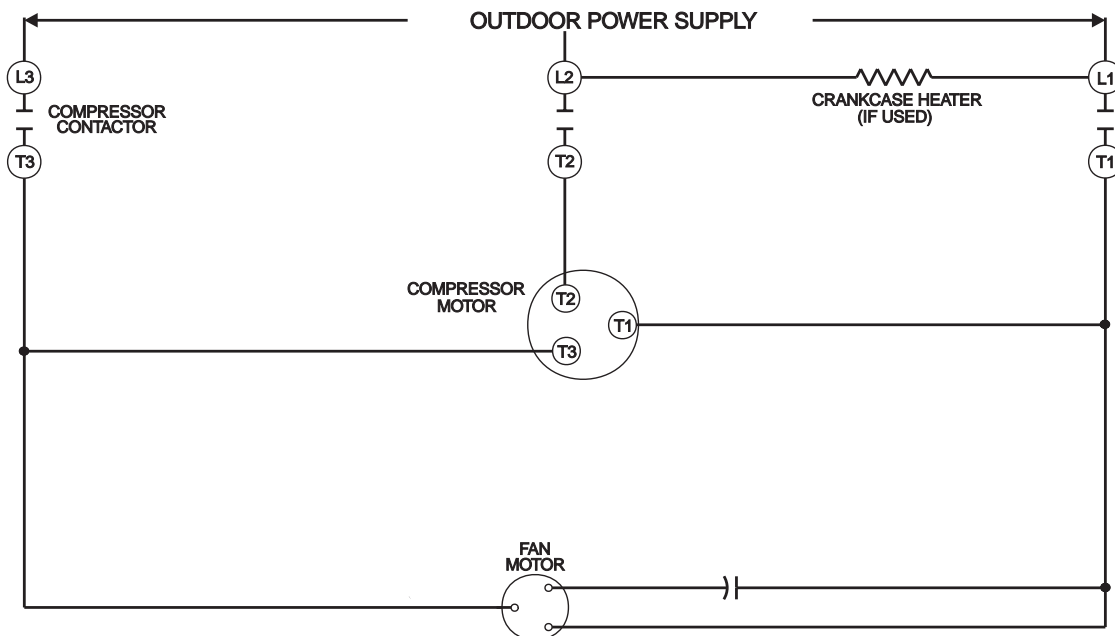

TYPICAL SCHEMATIC OF CONTROL CIRCUIT

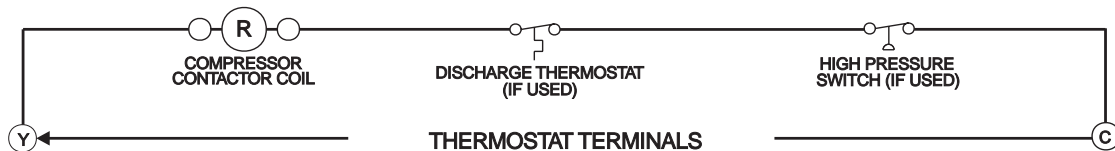

PART NO. 38942D005

CONNECTION DIAGRAM

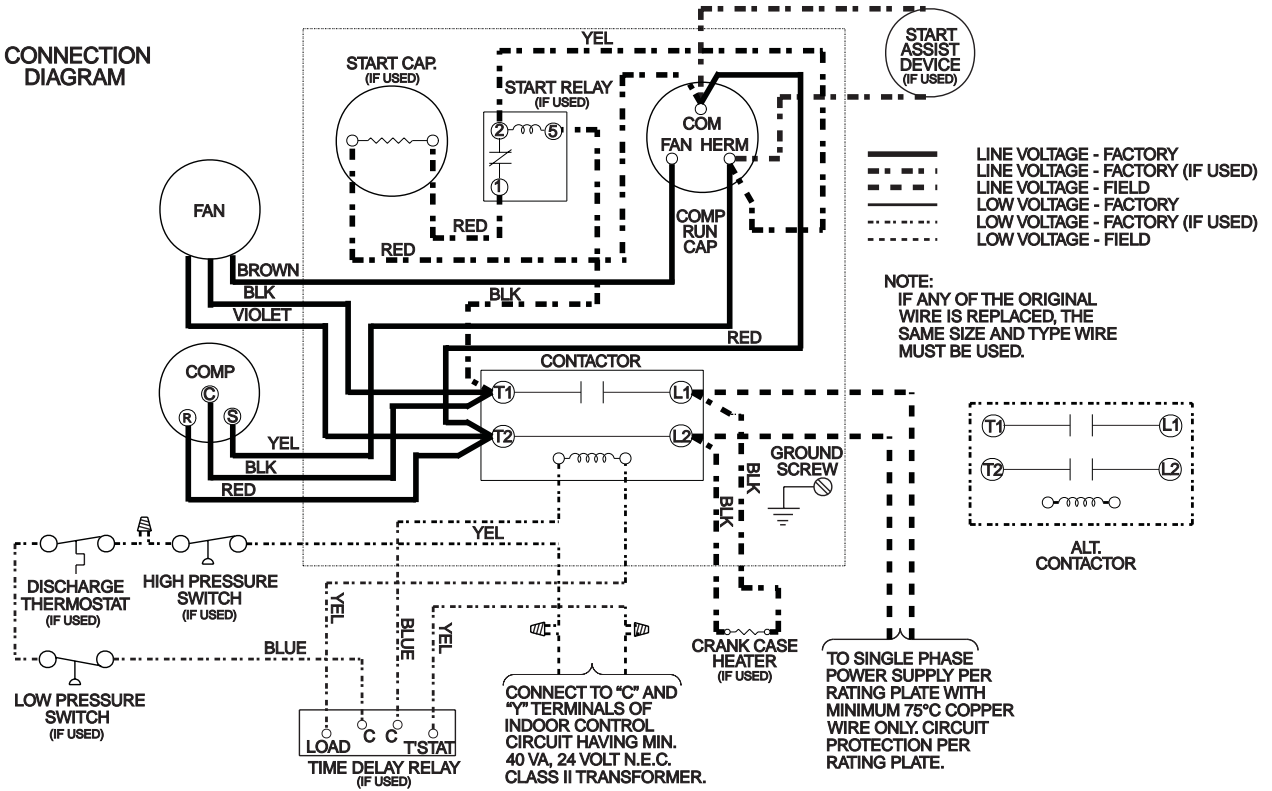

SCHEMATIC OF POWER CIRCUIT

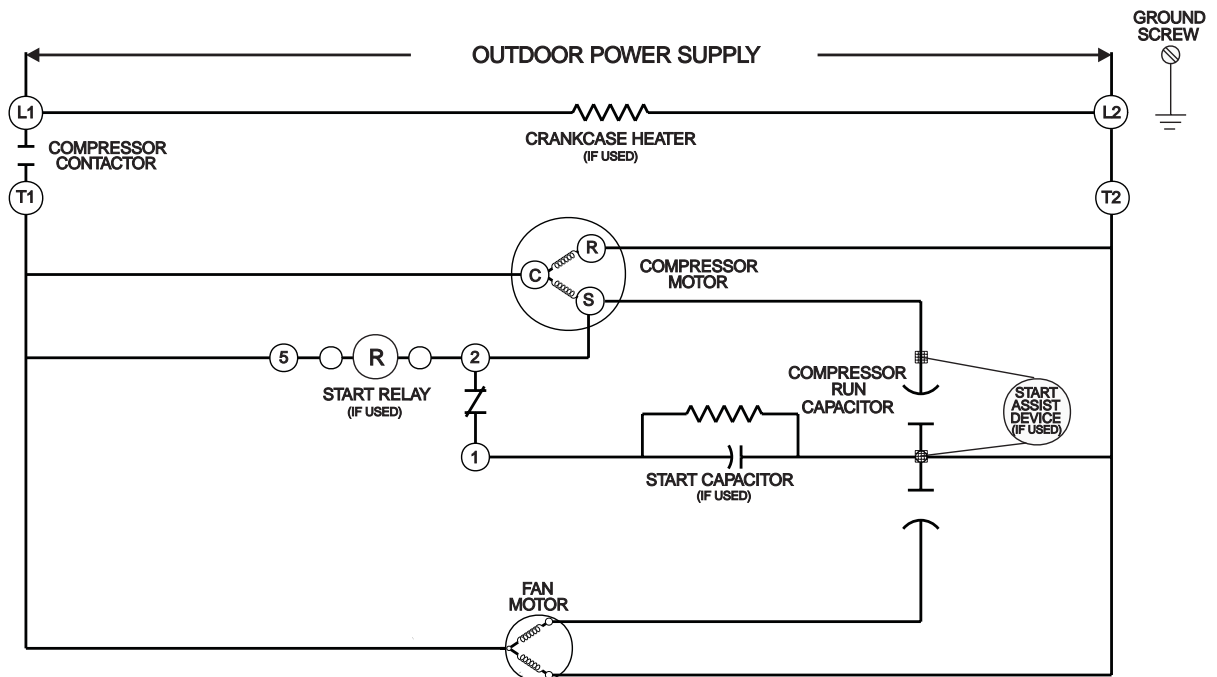

TYPICAL SCHEMATIC OF CONTROL CIRCUIT

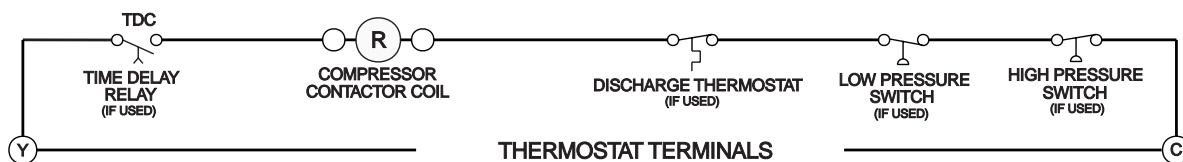

PART NO. 38602D008

Limited Warranty

August 1, 1997

This warranty gives you specific legal rights and you may have other rights which vary from state/province to state/province.

Warrantor: Armstrong Air Conditioning Inc., 421 Monroe St., Bellevue, OH 44811

Armstrong Air Conditioning Inc. products are available under the following names: Air Ease, Armstrong Air, American Aire, Concord

Subject to the limitations stated in this warranty, we warrant to the first buyer for use the residential heating, cooling or heat pump unit, when installed, operated and maintained as required by this warranty, to be free of defects in workmanship or material for a period of five years (two years for commercial equipment) from the time of installation. We will replace any defective component without cost or expense to you except for the costs of delivery and labor for removal and replacement of the defective component.

The SCU 12, 13 and E Series carry a 10 year compressor warranty. All other SCU Series air conditioners carry a 5 year compressor warranty.

Warranty Begins

The warranty period begins when the installation is complete and the product is ready to operate. You must be able to verify this date whenever a warranty claim is made. Original bill of sale, installer's invoice or other similar document will suffice. If the beginning date cannot be verified, we will consider warranty coverage to begin six months after the date the product was shipped from our factory.

Limitations on Implied Warranties

Implied warranties of merchantability or, to the extent applicable, fitness for a particular purpose are limited to five years, the same duration as the basic limited written warranty provided herein. Some states/provinces do not allow limitations on how long an implied warranty of merchantability or fitness lasts, so the above limitations or exclusions may not apply to you.

Only Warranty

This written Limited Warranty is the only warranty made by the warrantor; this warranty is in lieu of and excludes all other warranties, express or implied. The warrantor does not authorize any person to provide any other warranty or to assume for it any further obligation in connection with the warranted product.

What is NOT Covered

1. Cabinets or cabinet pieces.
2. Normal maintenance items such as filters, fan belts, fuses or other consumable items.
3. Damage caused by misuse, failure to maintain properly, accidents or acts of God.
4. External wiring, piping, venting or attachment of accessory products not integral to our product, including without limitation, humidifier, air cleaner, vent damper, thermostat or other mechanical devices not manufactured by the warrantor.
5. Products that have been operated in a corrosive atmosphere where a concentration of acids, halogenated hydrocarbons or other corrosive elements causes deterioration to metal surfaces or integral components. NOTE: Operation in a corrosive atmosphere is considered abuse and voids this warranty.
6. Products that have NOT been installed in accordance with our published installation instructions, applicable local, state/provincial or national codes, ACCA published standards.
7. Products that have NOT been installed by competent, qualified installers.
8. Products that have been moved from their original place of installation.

Warranty on Replacement Components

Any replacement component furnished by us will assume the remaining (unused) portion of the Limited Warranty.

Consequential Damages

The warrantor shall not be responsible for any consequential damages caused by any defect in the product. Some state/provinces do not allow the exclusion or limitations of incidental or consequential damages, so the above limitation or exclusion may not apply to you.

NOTE: After the first year, in the event that a gas or oil heat exchanger is no longer being manufactured by the warrantor, the warrantor will allow a credit equal to the then current wholesale price of an equivalent heat exchanger towards the purchase of a new Armstrong gas or oil furnace.

This product must be installed, used and cared for in accordance with the instruction manual. You are responsible for required periodic maintenance or service, such as changing or cleaning of air filters and lubrication or cleaning of components. Failure to properly install, operate or maintain your unit voids this warranty.

Owner Record

Model # _____ Serial # _____ Installation Date _____

INSTALLED BY:

Dealer _____

Address _____

Telephone # _____ License # _____